



## Kunststoffmühlen

*Von der kleine Beistellmühlen bis zur grosse  
Zentralmühlen*



### CMG-MÜHLEN

CMG Granulatori verfügt über ein komplettes Mühlenprogramm. Ob kleine Beistellmühlen oder grosse Zentralmühlen, allesamt mit einem grossen Zubehörprogramm und kundenspezifischen Modifikationen. Unser Engineering entspricht dem neusten technologischen Standard und wird ständig weiterentwickelt. Dies ermöglicht es und, auf ihre speziellen Wünsche einzugehen und so Anlagen anzubieten die ihnen einen kurzfristigen Rückfluss ihrer Investitionen gewährleistet. Qualität ist unser Markenzeichen. Ausgereifte Technik, beste Qualität aller Einzelkomponenten, ein hohes Mass an Fertigungsgenauigkeit sowie strengste Qualitätskontrolle garantieren ihnen extrem hohe Qualität aller CMG Granulatori Produkte.

### VORTEILE

- Vielseitigkeit
- Wirtschaftlichkeit
- Zuverlässigkeit
- Sicherheit
- Schall
- Sicherheitsschalter garantieren eine optimale Sicherheit für den Bediener.
- Ein Überwachungssystem kontrolliert ständig die Sicherheitsschalter und deren Verkabelung. Bei einem Problem wird die Mühle automatisch abgeschaltet und der Defekt wird durch eine Lampe angezeigt.



# GEIGER CYTEC SYSTEMS

## B17 Serie

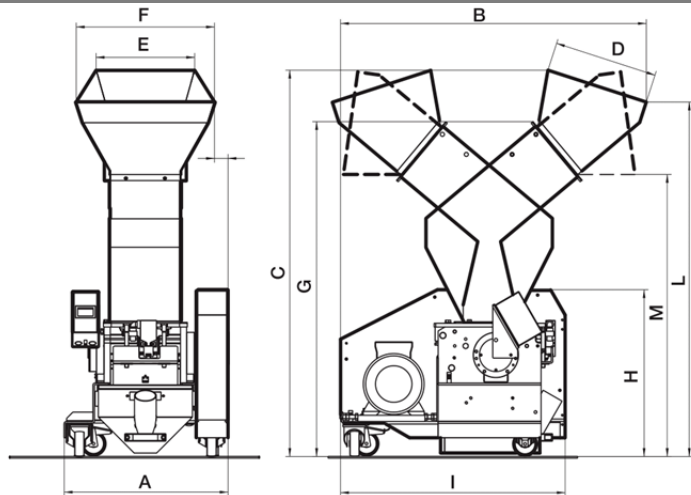

	mm	N°	N°	mm	u/m	KW	Ø	Kg/h
17-22-3K	327x315	3	2	170	250	2.2	5	30-50
B17-38-3K	327x465	3	2	170	250	2.2	5	50-

	A	B	C	D	E	F	G	H	I	L	M
B17-22-3K	525	980	1237	327	316	443	1072	534	720	1135	903
B17-38-3K	675	980	1237	327	465	593	1072	534	720	1135	903

## G17-Serie

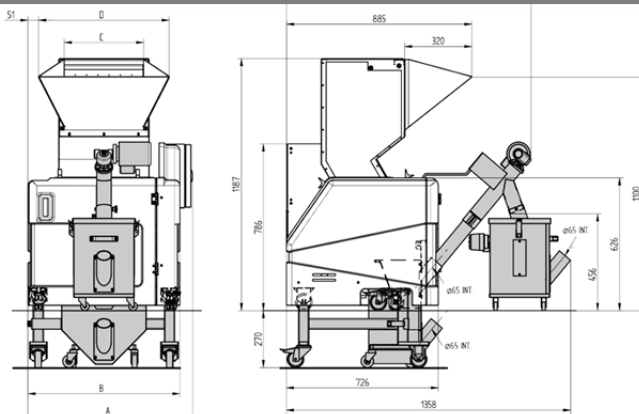

	mm	N°	N°	mm	u/m	KW	Ø	Kg/h
G17-22	327x315	9 (3)	2	170	135-155(275)	2.2 (3-4)	5	30-50
G17-38	327x465	15 (3)	2	170	135-155(275)	2.2 (3-4)	5	50-90

  

	A	B	C	D	E	F	G	H	I	L	M	N	O	P
G17-22	649	982	1234	327	315	443	1071	535	720	1132	906	537	955	1160
G17-38	724	982	1234	327	465	593	1071	535	720	1132	906	537	955	1160



# GEIGER CYTEC SYSTEMS

## G25-Serie

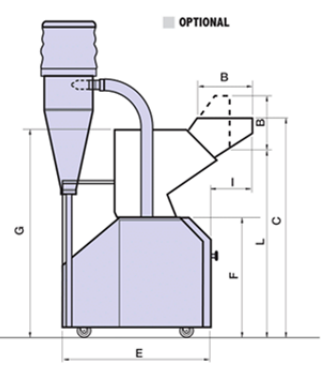
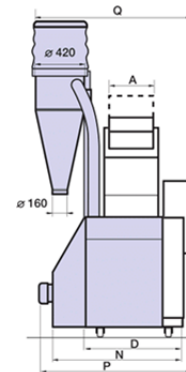
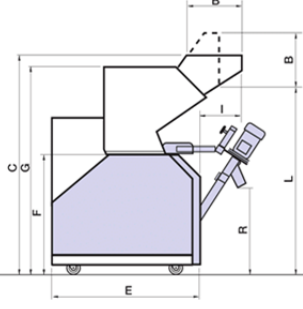
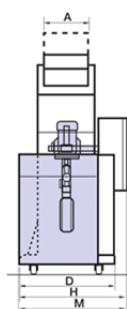

mm

N°

N°

mm

u/m

KW

Ø

Kg/h

G25-30	380x311	3 (2-12)	2	250	340 (450-180)	4 (5.5)	8	40-140
G25-45	380x457	3 (2-18)	2	250	340 (450-180)	5.5 (7.5)	8	120.200

	A	B	C	D	E	F	G	H	I	L	M	N	R	P	Q
G25-30	311	380	1530	660	1035	835	1460	735	283	1315	740	875	620	1045	1087
G25-45	457	380	1530	805	1035	835	1460	880	283	1315	885	1020	620	1190	1232

## S30-Serie

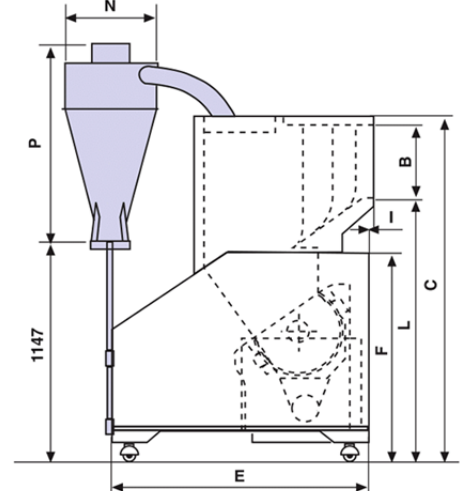
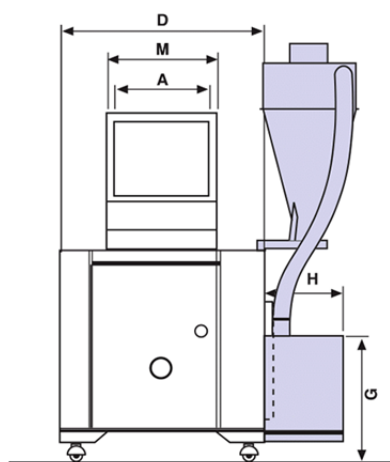

mm

N°

N°

mm

u/m

KW

Ø

Kg/h

S30-50	305x510	3	2	305	460	8	250-340	S30-50
--------	---------	---	---	-----	-----	---	---------	--------

	A	B	C	D	E	F	G	H	I	L	N	P
S30-50	510	305	1702	1019	1102	1034	522	450	15	1350	420	900

OPTIONAL



GEIGER Cytec Systems AG  
Vorstadt 40  
CH-3380 Wangen an der Aare



+41 31 734 24 24



www.geigercytec.com



info@geigercytec.com